



***HandPad*: Enabling On-the-Go Writing on Your Hand via Human Capacitance**

Yu Lu[†], Hao Pan[†], Dian Ding^{†*}, Yijie Li[†], Juntao Zhou[†],
Yongjian Fu [◆], Yongzhao Zhang[‡], Yi-Chao Chen[†], Guangtao Xue[†]

Shanghai Jiao Tong University[†]

Central South University [◆]

University of Electronic Science and Technology of China[‡]

VR/AR is Everywhere



Immersive Entertainment



Education and Researches

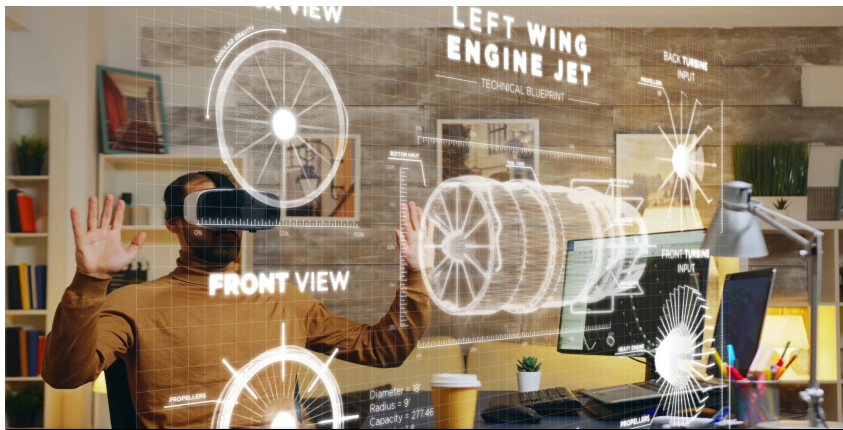

Training and Simulation



Medical Treatment and Remote Inquiry

Text Input is Critical for VR/AR



◆ Precision

◆ Customization

◆ Privacy

Existing Methods

Wireless Signal



◆ Privacy & Disturbance

Inertial Sensor

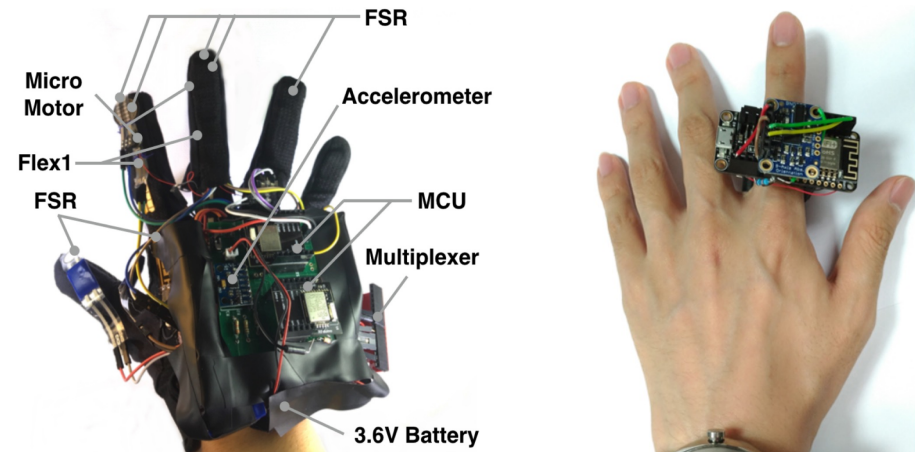

◆ Complex Deployment

More Suitable Method ?



◆ Traditional Touchscreen

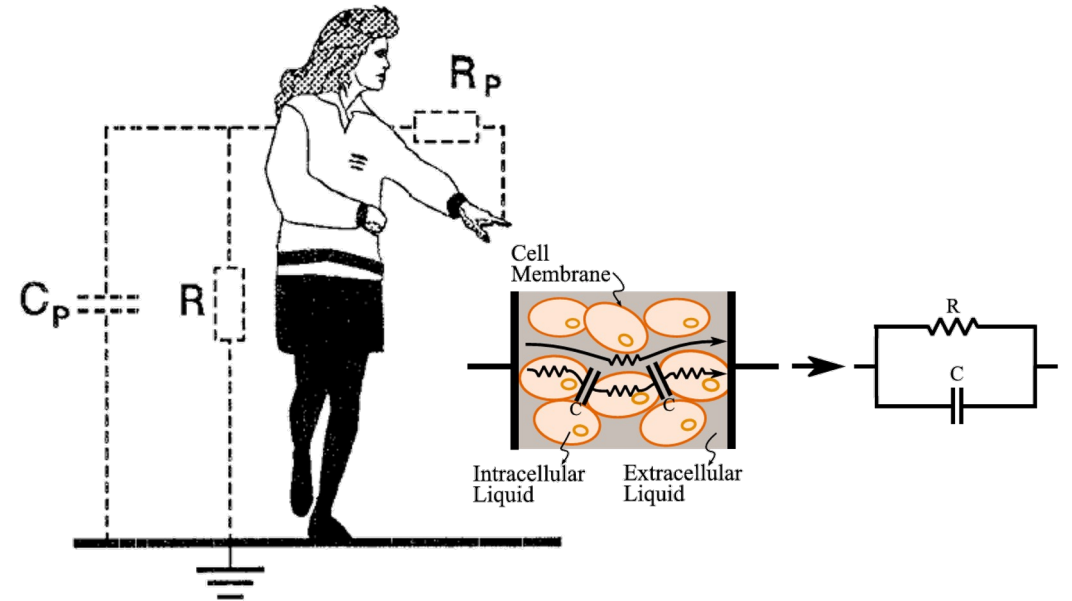

◆ Human Capacitance

Modeling Human Capacitance

Human Arms Capacitance Model

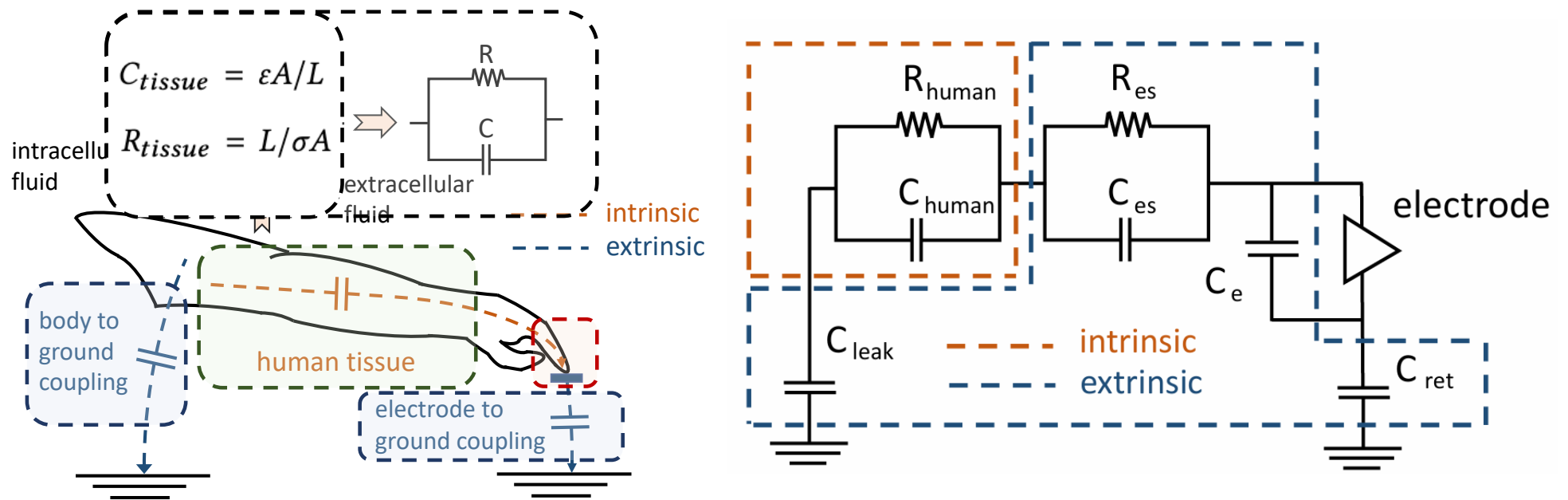

Modulation of Human Capacitance

Extrinsic capacitance remains constant, we can modulate measured capacitance value by changing the **intrinsic capacitance (i.e., touch on human body)**

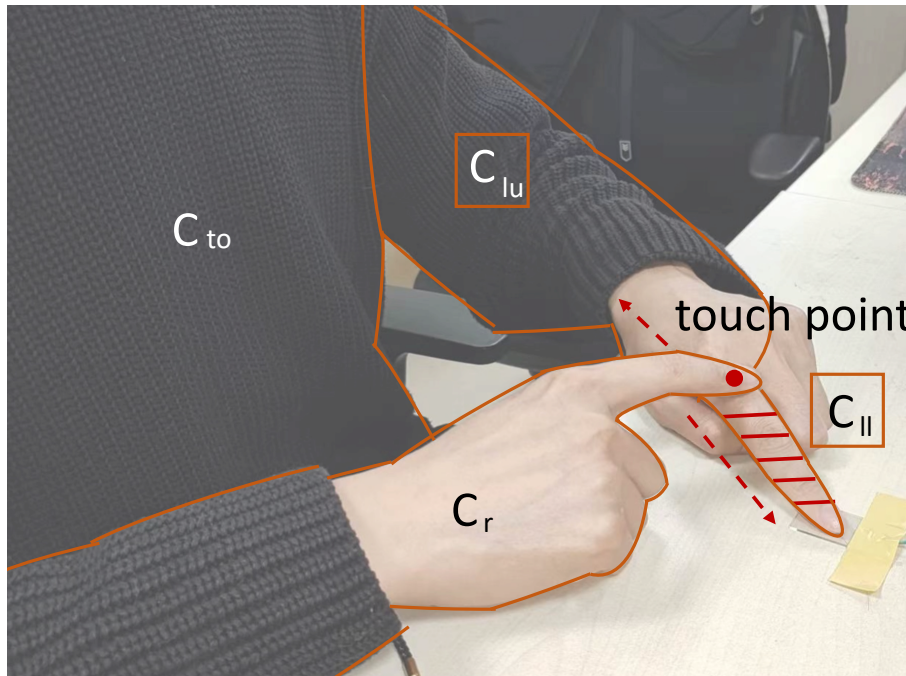

$$C_{tissue} = \epsilon A/L$$
$$C_{in} = \frac{1}{\frac{1}{C_{to}} + \frac{1}{C_r + C_{lu}} + \frac{1}{C_{ll}}}$$

change with the touch point

intrinsic

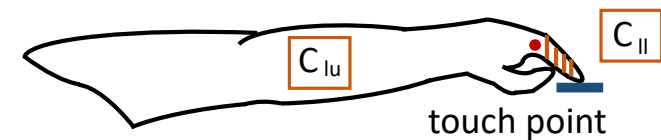

HandPad Setup

Turn your hands into a **handwriting interface**

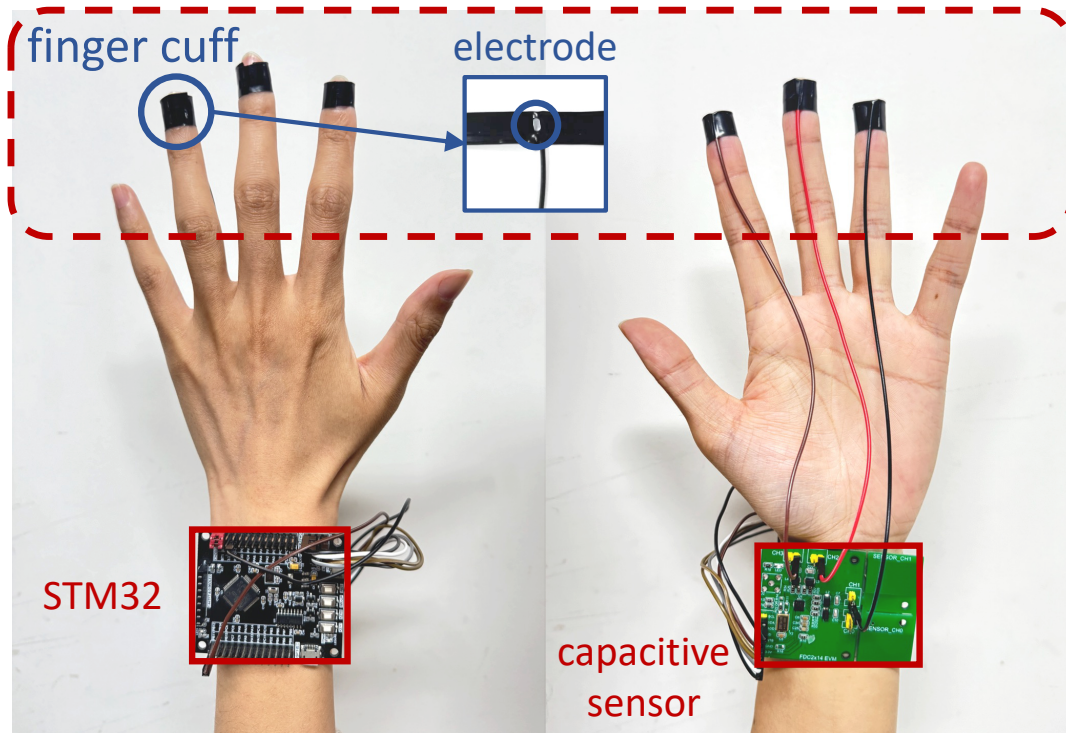

Demo Video

Human Capacitance **Modulated by Touching Point**



Channel 1

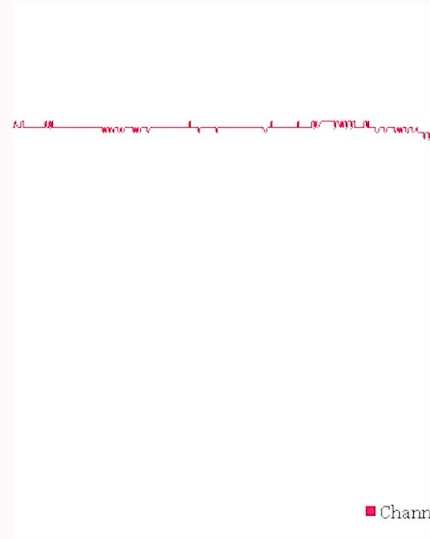

Input Mode I: Keystroke

Capacitive Sensor can **Locate Touching Point**

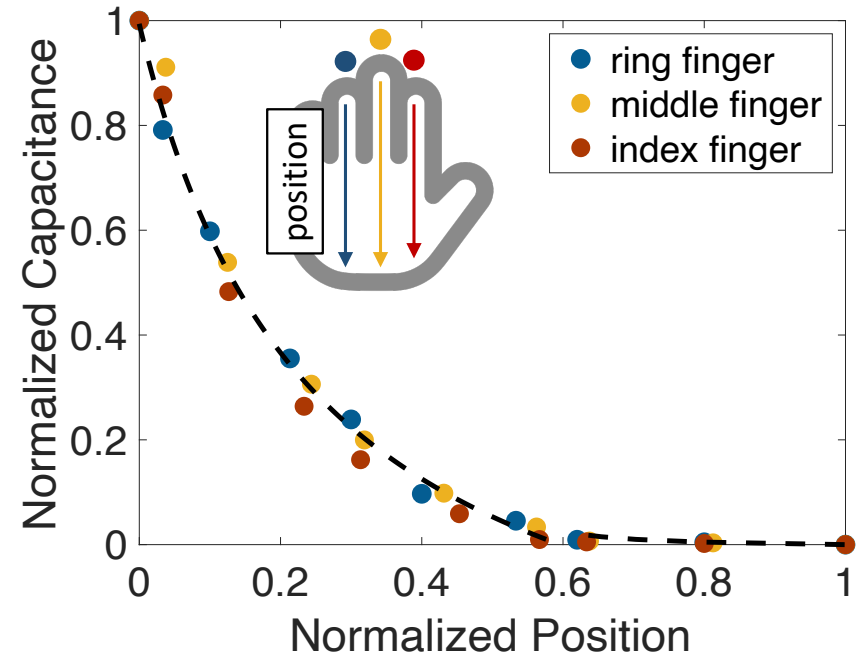
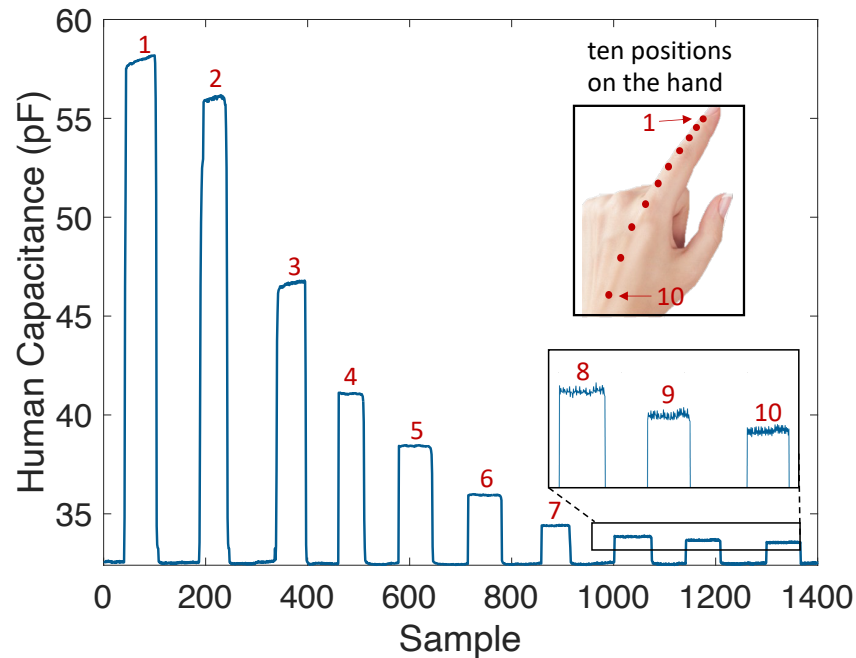

Input Mode II: Handwriting

Human Capacitance **Modulated by Touching Point**

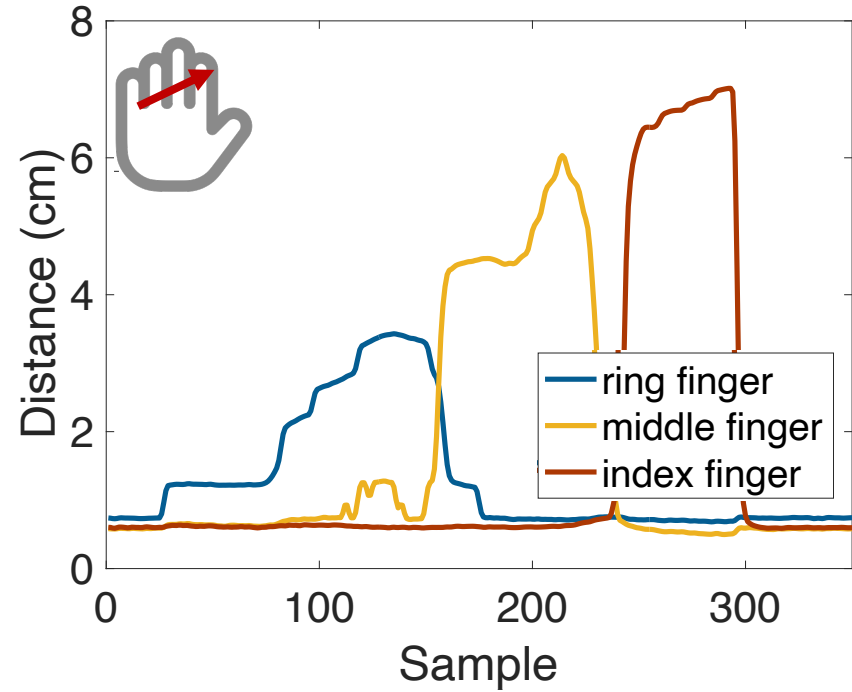
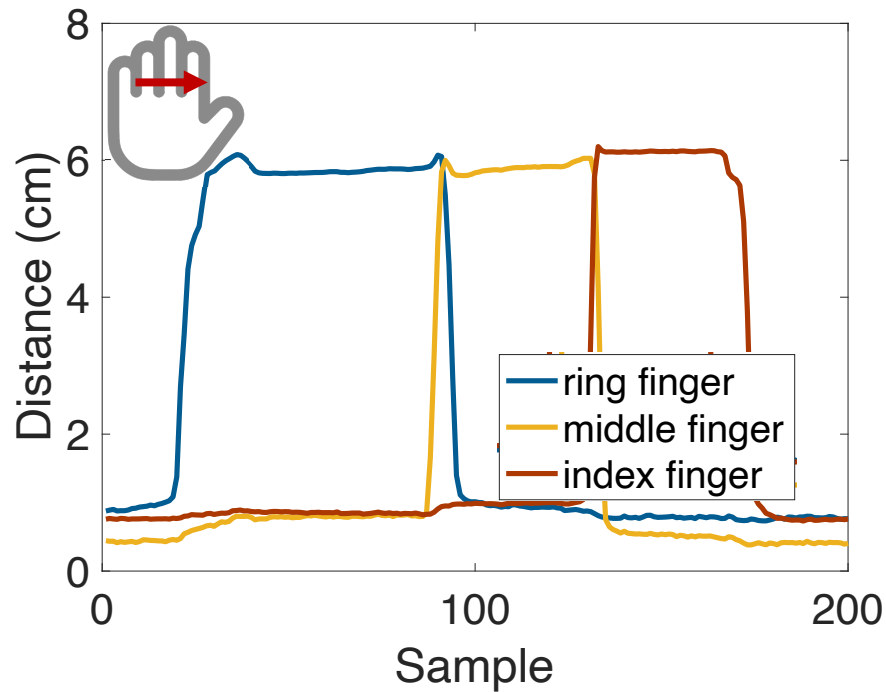

System Overview of HandPad

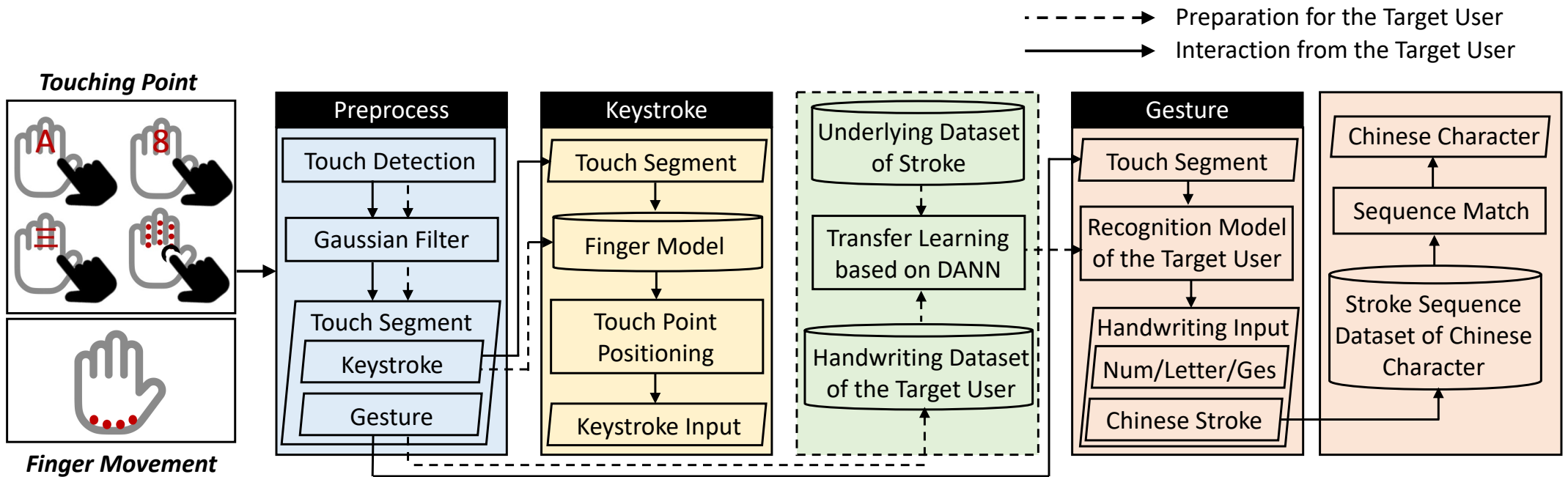

Signal Preprocess

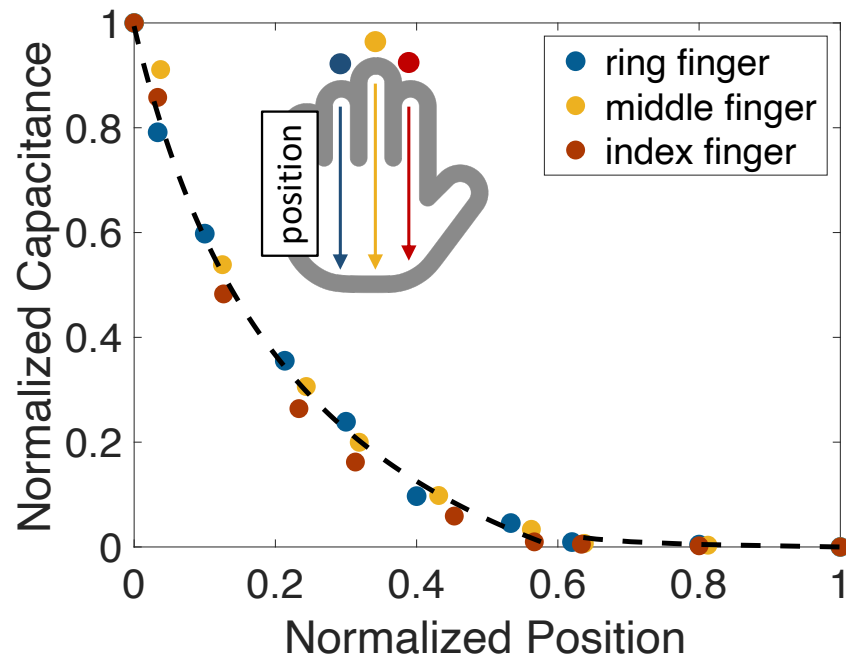

1. Finger Model

$$d = \frac{\alpha_i}{b * C_{human} + 1} + \beta_i$$

2. Preprocess

Gaussian Filter

Keystroke

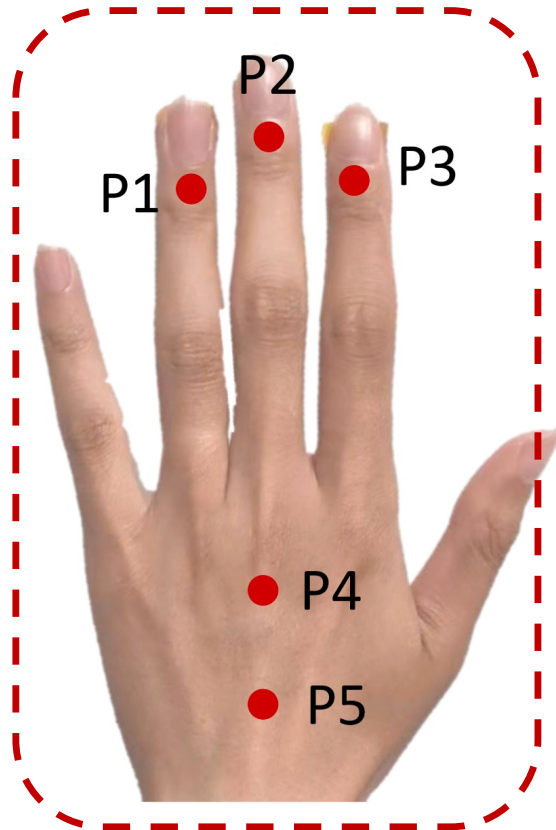

1. Calibration

Finger Model

2. Keystroke

*Preprocess
Segmentation
Recognition*

Handwriting Input

1. Dataset Collection *(underlying dataset)*



Handwriting Number (0 - 9)

Handwriting Letter (A - Z)

Handwriting Chinese Stroke

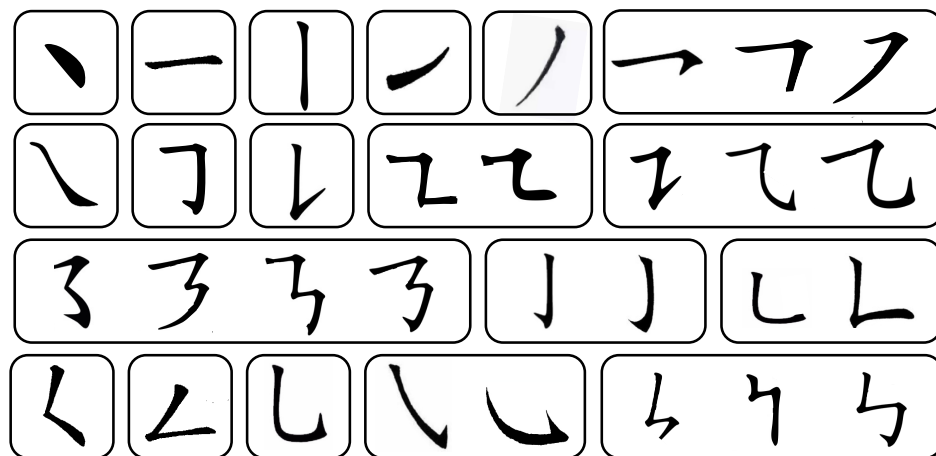

26 strokes to 19 classes

Handwriting Input

2. Signal Recognition

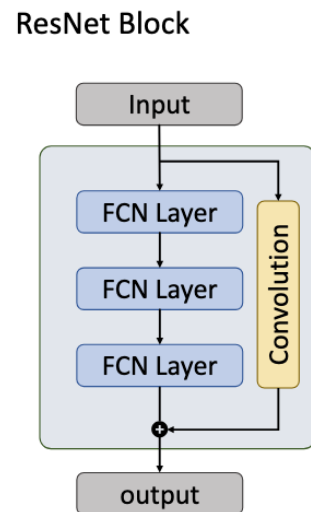
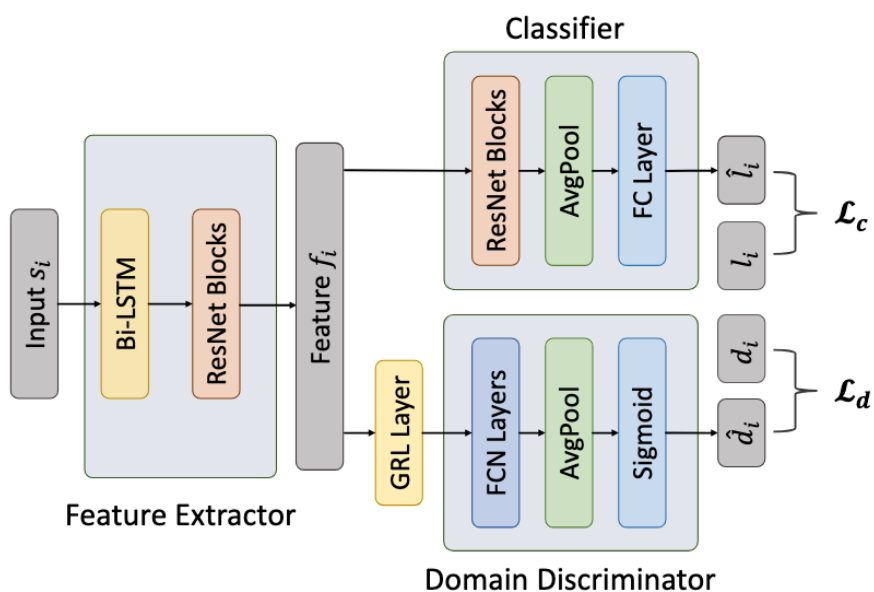

1. Underlying Model

2. Domain Adversarial Neural Network

Target User

Database for each input

Domain Transfer

3. Sequence Matching

Chinese Character

Evaluation - Keystroke

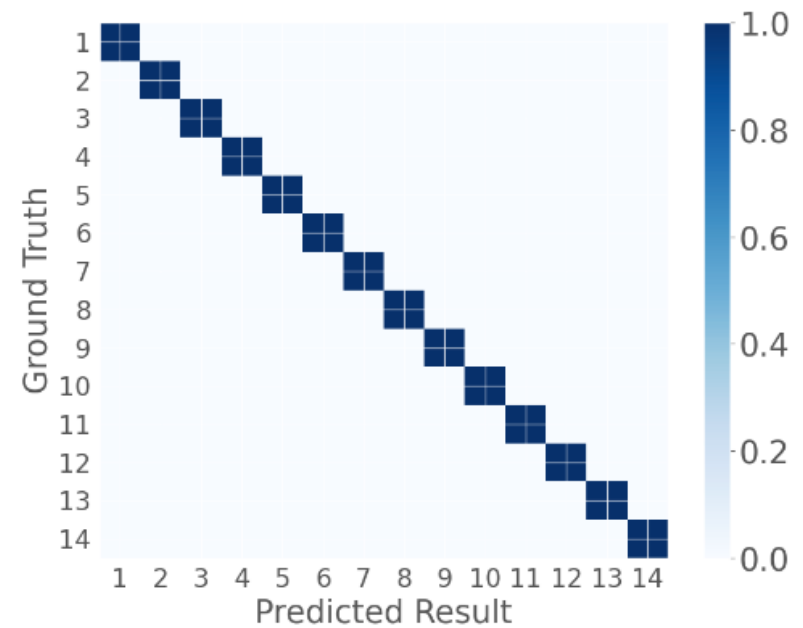
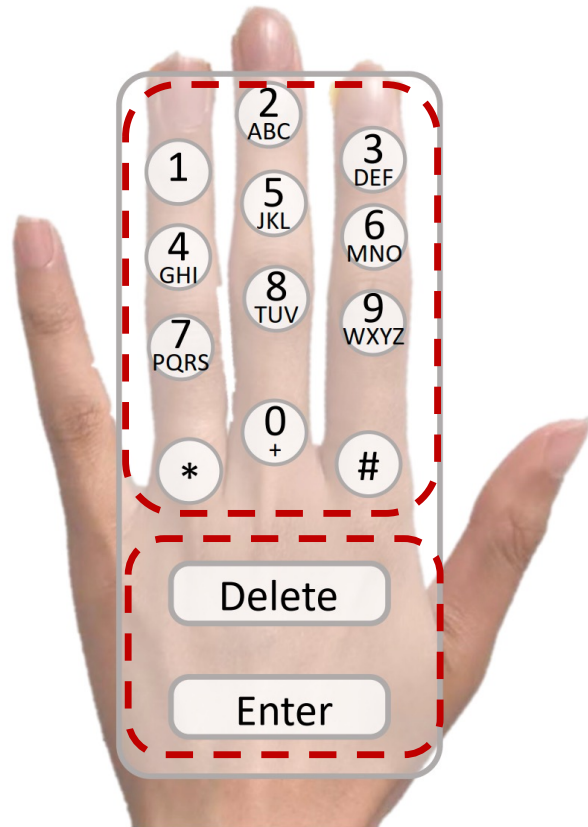

Average Accuracy: 100%

Evaluation - *Letter and Number*

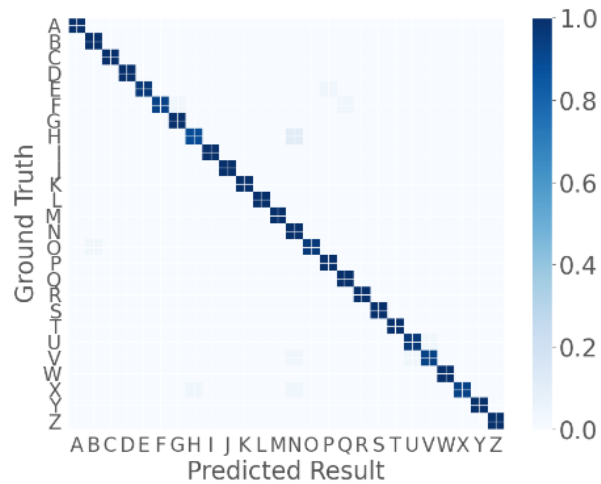

Letter Accuracy
99.1%

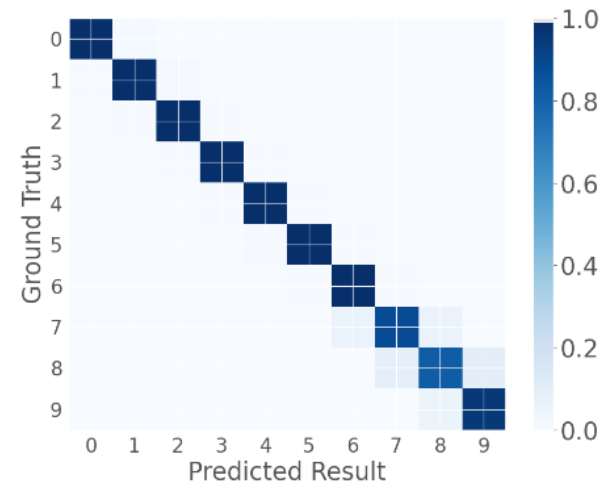

Number Accuracy
97.6%

Evaluation – Chinese Character

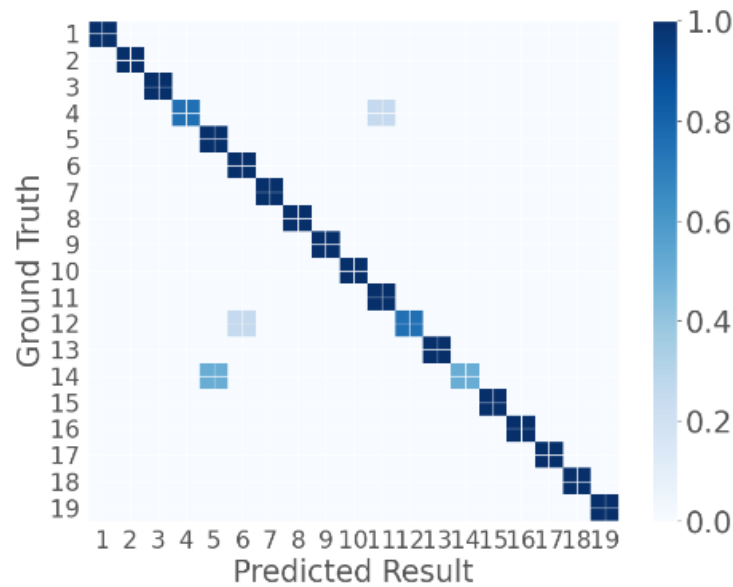
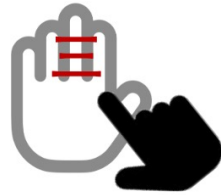

Stroke Accuracy
94.6%

20795 Chinese Character

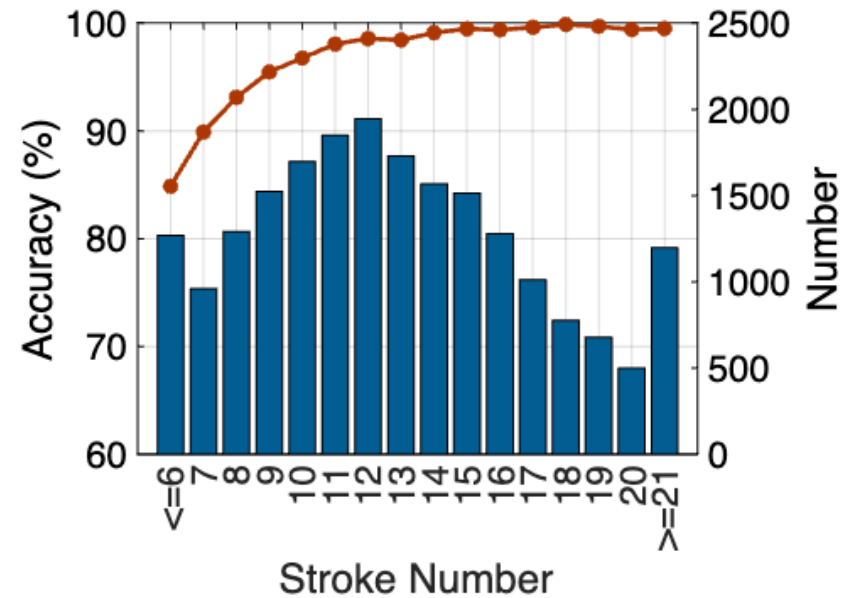

Character Accuracy
97.9%

Evaluation

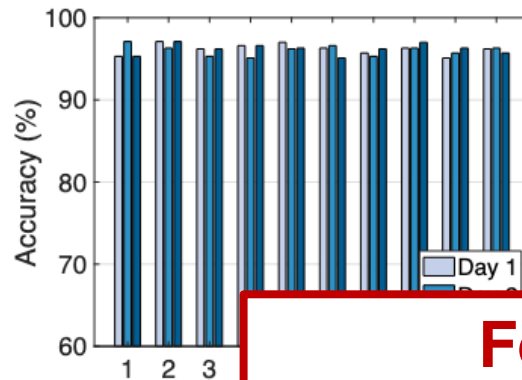

Influence of different user

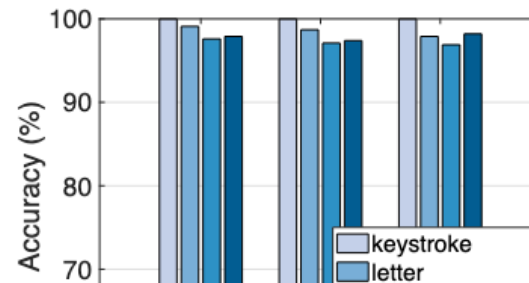

Influence of different environment

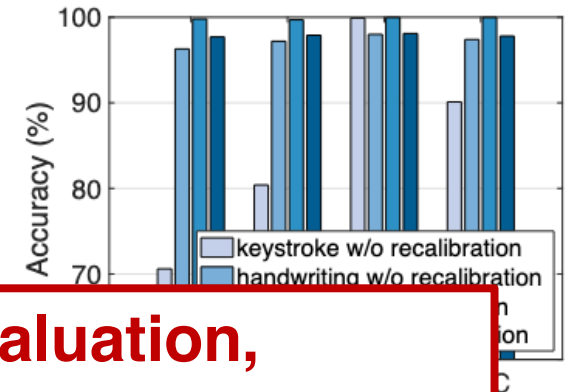

Influence of different temperature

For more detail about the evaluation, please refer to our paper.

Conclusion

- We built the **capacitive sensing system for text input**.
- We validate **human capacitance based finger touching**.
- HandPad achieves **High accuracy for keystroke and handwriting input**.

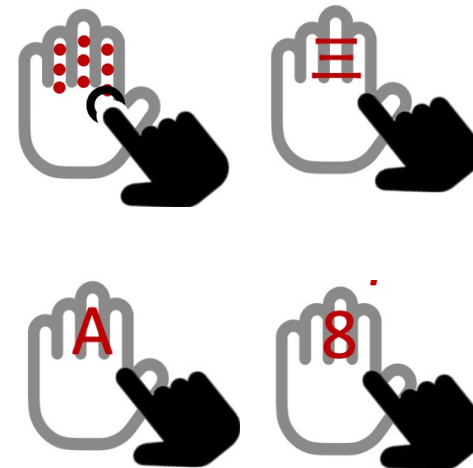
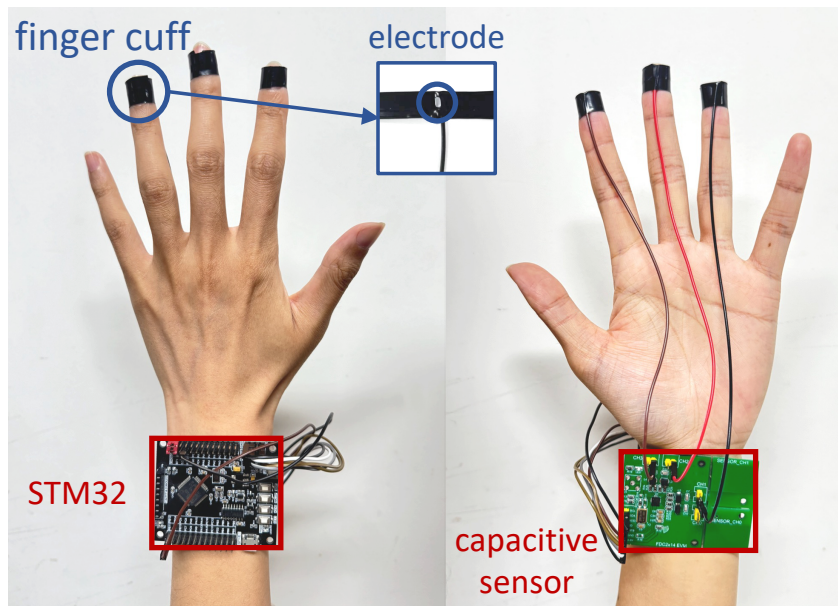



Thanks for listening!

Any questions, you can contact:

Dian Ding,

dingdian94@sjtu.edu.cn